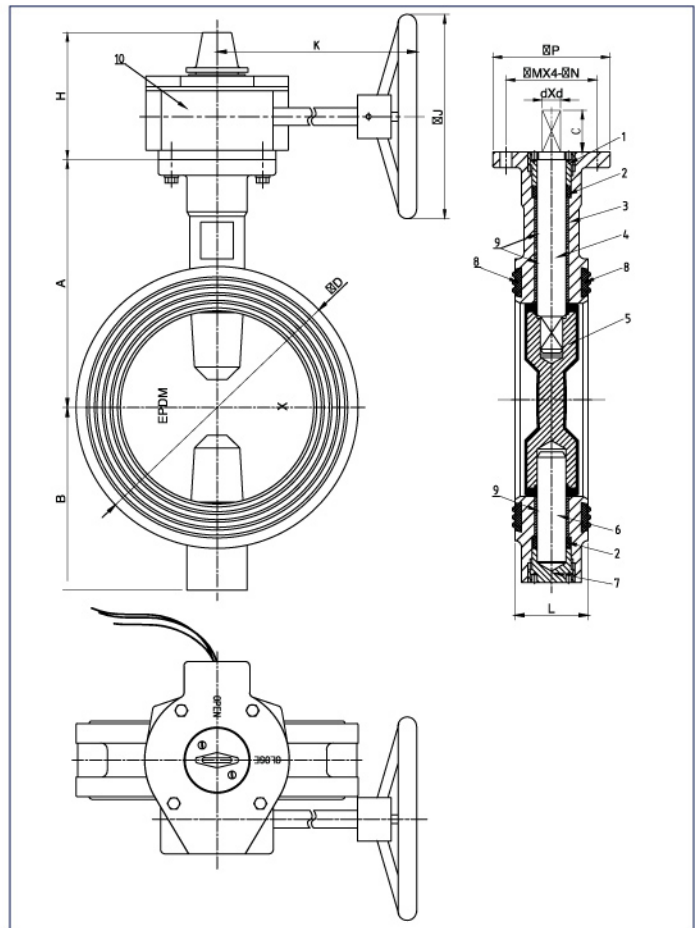

**Wafer Type Butterfly Valve,UL/ULC Listed,FM Approved****Model No.:WD-371X****Technical Specifications:**

- 1.Maximum Working Pressure:300PSI(Max.Test Pressure:600PSI)
- 2.Maximum Working Temperature:250 F (120 C)
- 3.Application: Indoor and Outdoor Use
- 4.Double-Seal Disc:Resilient EPDM Coated
- 5.Factory Installed Supervisory Tamper Switch Assembly

**SIZE CHART**

ITEM SIZE	A	B	C	D	H	K	J	P	M	N	d	L	
2"	110	85	32	100	111	153	218	152	90	70	9	10	42
2-1/2"	125	95	32	112	111	153	218	152	90	70	9	10	44.2
3"	140	100	32	120	111	153	218	152	90	70	9	11	45.3
4"	160	100	32	161	111	153	218	152	90	70	9	14	52
5"	170	125	32	182	111	153	218	152	90	70	9	14	54.4
6"	190	140	32	216	111	153	218	200	90	70	9	16	55.8
8"	230	175	32	260	126	210	232	300	125	102	12	19	60.5
10"	260	200	45	320	126	210	232	300	125	102	12	24	66.5
12"	300	240	45	375	161	249	350	150	125	14	26	76.9	

**Carried Standard**

Design Standard	API609
Face to Face Standard	ASME B16.10
Top flange Standard	ISO 5211
Test Standard	FM1112 / UL1091

10	Signal Gearbox	DI
09	Stem Bushing	PTFE
08	End Face Seal	EPDM
07	Lower Shaft Sealing Nut	WCB
06	Lower Shaft	SS416
05	Disc	DI+EPDM
04	Upper Shaft	SS416
03	Body	DI
02	Shaft Seal	EPDM
01	Upper Shaft Sealing Nut	WCB
<b>NO.</b>	<b>Name</b>	<b>Material</b>